

### Features

- Welded type crystal units
- All standard frequencies
- Frequency range from 4MHz to 200MHz
- Excellent aging characteristics
- Uniform frequency tuning range and modulation sensitivity
- Applications: TV, STB, LCDM, Communications, Consumer Devices, Cable Modem, etc.
- RoHS Compliant & Pb-Free



### Standard Specification

Type	6D Through-hole Crystal		
Frequency Range	4~24MHz	24~100MHz	100~200MHz
Overtone Order	Fundamental	3rd Overtone	5th /7th Overtone
Load Capacitance	Series or 9pF~50pF		
Drive Level	1~500μW Max. (100μW Typ.)		
Frequency Tolerance	±10ppm, ±20ppm, or specify		
Series Resistance	40~100Ω	40~80Ω	100Ω
Operating Temperature	-20~+70°C, -40~+85°C		
Storage Temperature	-55~+125°C		
Shunt Capacitance	7pF Max.		
Aging (at 25°C)	±5ppm /Year Max.		
Packing Unit	200pcs		

**Dimensions (mm)**

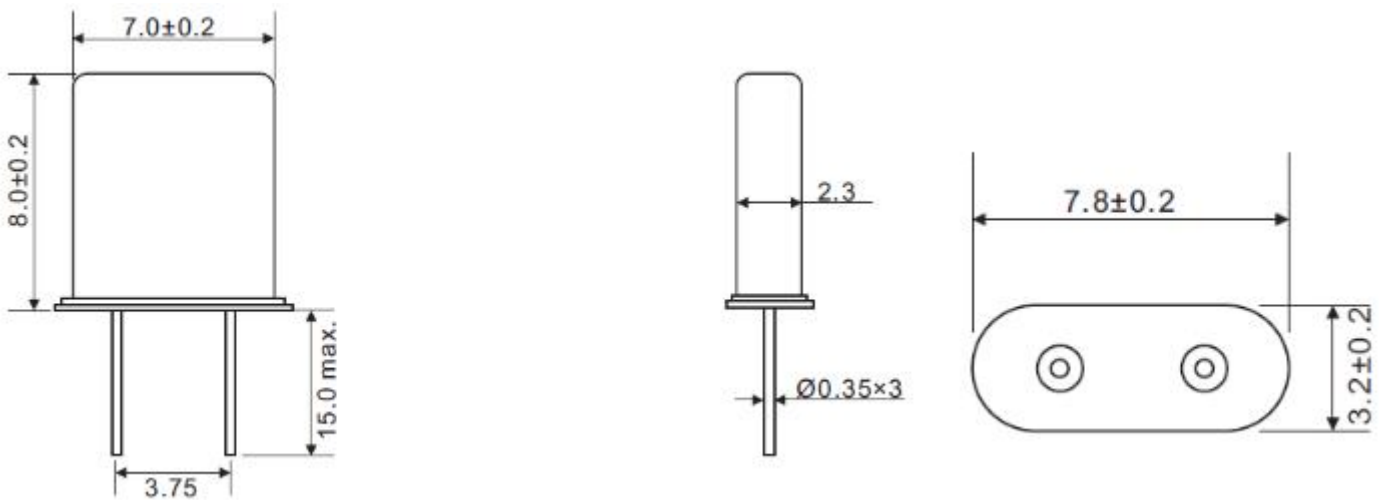

**Part ordering information**

X	-6D	-45.000	-32	-10	-60	-C
	Series	Frequency	Load Capacitance	Tolerance	ESR	Temperature Range
		e.g	e.g	e.g	e.g	e.g
		45.000 = 4MHz	32 = 32pF	10 = 10ppm	60 = 60Ω	A= -10~+60°C B= -20~+70°C C =-40~+85°C D =-40~+105°C E =-55~+125°C

### Reliability Tests Specification

Test item	Equipment	Condition	Specification
1.SOLDERABILITY TEST	SJK-REL001、RC-328A	1. Solderability:235±5°C, 5±0.5S 2. Heat resistance:260±5°C,10±1S restoration of 1 hour	MIL-STD-883E Method 2003.7
2. HERMETICITY TEST	HELIOT-306S	FC-84 FLUOROCARBON,BUBBLE MACHINE	MIL-STD-883E Method 1014.10
3. VIBRATION TEST	HG-V4、S&A 250B	Enable Crystal(10g) from 10-55-10Hz,X、Y、Z horizontal,1 Minute vibration/time, 1time/ 2 hours.	MIL-STD-883E Method 2007.3
4.MECHANICAL SHOCK	HPC-200、S&A 250B	Enable Crystal 50G(490m/s2) time=11 ms speed=3.4 m/s half sine wave oscillation	JIS C6701
5. DROP TEST	HARD BOARD.S&A250B	75CM HIGH,3 TIMES ON HARD BOARD	MIL-STD-202F Method 213B
6. HIGH & LOW TEMP STORAGE TEST (Static test)	H-PTH-80CK & HM101-3ABN , S&A 350B/250B	High temperature: 125°C±2°C,1000hr; Low temperature:-40°C±3°C,1000hrs	MIL-STD883C, METHOD 1011.8
7.TEMP & HUM CYCLING TEST	H-PTH-80CK CHAMBE , S&A 350B/250B	Temperature:-10°C±2°C~65°C±2°C,Humidity:93±3%,1 cycle need 24 hrs. 5cycles.	MIL-STD-883E Method 1005.8
8. HIGH TEM. & HUM. STORAGE TEST	H-PTH-80CK CHAMBE , S&A 350B/250B	Temperature:40°C±2 , Humidity:85+3,- 2%,Store 96 hrs	JIS C6701
9.AGEING TEST	H-PTH-80CK CHAMBE , S&A 350B/250B	Temperature:40°C±2 , Humidity:85+3,- 2%,Store 96 hrs	JIS C5023



**X-6D Series**  
**Through Hole Crystal**  
**Size: 7.8×3.2×8.0mm**  
**4~200 MHz / 9~50 pF / 10~20ppm**

---

- Any and all XREF ELECTRONICS products described or contained herein do not have specifications that can handle applications that require extremely high levels of reliability, such as life-support systems, aircraft control systems, or other applications whose failure can be reasonably expected to result in serious physical and/or material damage. Consult with your XREF ELECTRONICS representative nearest you before using any XREF ELECTRONICS products described or contained herein in such applications.
- XREF ELECTRONICS assumes no responsibility for equipment failures that result from using products at values that exceed, even momentarily, rated values (such as maximum ratings, operating condition ranges, or other parameters) listed in products specifications of any and all XREF ELECTRONICS products described or contained herein.
- Specifications of any and all XREF ELECTRONICS products described or contained herein stipulate the performance, characteristics, and functions of the described products in the independent state, and are not guarantees of the performance, characteristics, and functions of the described products as mounted in the customer's products or equipment. To verify symptoms and states that cannot be evaluated in an independent device, the customer should always evaluate and test devices mounted in the customer's products or equipment.
- XREF ELECTRONICS strives to supply high-quality high-reliability products. However, any and all semiconductor products fail with some probability. It is possible that these probabilistic failures could give rise to accidents or events that could endanger human lives, that could give rise to smoke or fire, or that could cause damage to other property. When designing equipment, adopt safety measures so that these kinds of accidents or events cannot occur. Such measures include but are not limited to protective circuits and error prevention circuits for safe design, redundant design, and structural design.
- In the event that any or all XREF ELECTRONICS products (including technical data, services) described or contained herein are controlled under any of applicable local export control laws and regulations, such products must not be exported without obtaining the export license from the authorities concerned in accordance with the above law.
- No part of this publication may be reproduced or transmitted in any form or by any means, electronic or mechanical, including photocopying and recording, or any information storage or retrieval system, or otherwise, without the prior written permission of XREF ELECTRONICS.
- Information (including circuit diagrams and circuit parameters) herein is for example only ; it is not guaranteed for volume production. XREF ELECTRONICS believes information herein is accurate and reliable, but no guarantees are made or implied regarding its use or any infringements of intellectual property rights or other rights of third parties.
- Any and all information described or contained herein are subject to change without notice due to product/technology improvement, etc. When designing equipment, refer to the "Delivery Specification" for the XREF ELECTRONICS product that you intend to use.
- Specifications and information herein are subject to change without notice.